

# SAN ONOFRE'S STEAM GENERATORS: SIGNIFICANTLY WORSE THAN ALL OTHERS NATIONWIDE

JULY 11, 2012

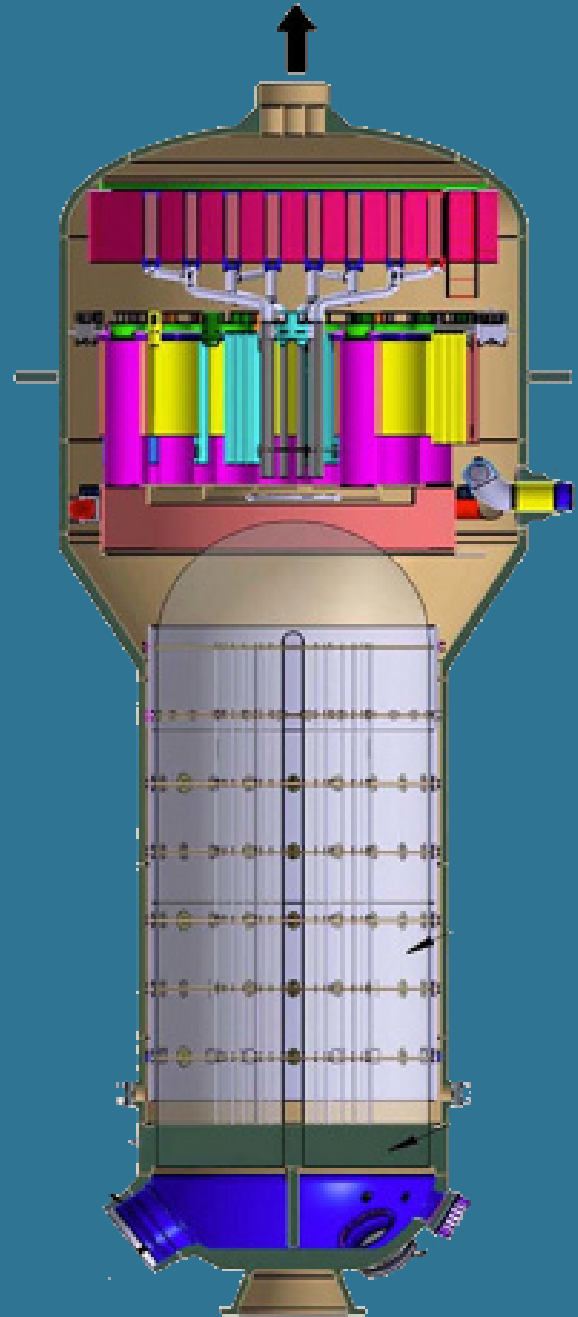

FAREWINDS ASSOCIATES

ARNIE GUNDERSEN, MENE  
FAREWINDS ASSOCIATES  
BURLINGTON, VERMONT, USA

REPORT COMMISSIONED BY FRIENDS OF THE EARTH

## **San Onofre's Steam Generators: Significantly Worse than All Others Nationwide**

### **Summary**

Using NRC publicly available data, Fairewinds compared the replacement steam generator plugging at both San Onofre Units 2 and 3 to the replacement steam generator plugging history for all other replacement steam generators at US nuclear power plants. Fairewinds concludes that San Onofre's has plugged 3.7 times as many steam generator tubes than the combined total of the entire number of plugged replacement steam generator tubes at all the other nuclear power plants in the US.

Using Edison's San Onofre *Condition Report* as a basis, Fairewinds also compared the damage and failure modes at San Onofre Unit 2 to Unit 3 and concludes that there is no difference in the failure modes between the two units and that both should remain shut down until extensive modifications or fabrication of replacement generators are completed.

### **The Damage to the Steam Generators at San Onofre Units 2 and 3 is the Worst Ever Experienced**

In March 2012, Edison announced that eight steam generator tubes in both San Onofre Units 2 and 3 had failed their pressure test and therefore would be plugged. As this process began, the general public and local officials were led to believe that these tube failures were a simple every day occurrence with a simple solution that would enable the reactors to restart quickly. However, at the June 18, 2012 AIT presentation, the NRC said,

“Throughout the US nuclear industry, this is the first time more than one steam generator tube failed pressure testing... Eight tubes failed. The pressure testing identified that the strength of eight tubes was not adequate and structural integrity might not be maintained during an accident... this is a serious safety issue.”

The US NRC promulgates all its own regulations and has given them the acronym NUREG. According to NRC NUREG-1841<sup>1</sup>, entitled *U.S. Operating Experience With Thermally Treated Alloy 690 Steam Generator Tubes*, the nuclear industry has had *no instances* in which Alloy 690, the thermally treated tube alloy used in the San Onofre replacement steam generators, lacked structural integrity and did not satisfy accident performance requirements.

**NUREG-1841, Section 4.2.3 Summary and Observations** “No instances have been reported in which a thermally treated Alloy 690 tube did not satisfy the criteria for structural integrity (e.g., three times the normal operating differential pressure). In addition, no instances have been reported in which a steam generator with thermally treated Alloy 690

---

<sup>1</sup> NRC NUREG-1841, March 2006, entitled U.S. Operating Experience With Thermally Treated Alloy 690 Steam Generator Tubes

tubing did not satisfy the accident-induced leakage performance criteria under these inspection strategies.”<sup>2</sup>

Therefore, according to NUREG-1841, San Onofre’s eight plugged tubes are an anomaly for the US nuclear industry. Remarkably, the situation at San Onofre Unit 2 and Unit 3 is decidedly worse than indicated in Edison’s March statements. In its May 15, 2012 press release Edison indicated that at total of 1317 tubes were plugged in San Onofre Units 2 and 3 rather than the mere 8 tubes originally delineated. At its June 18, 2012 Augmented Inspection Team (AIT) presentation, the NRC confirmed to the general public and California state and municipal officials that this extraordinarily high number of tubes had been plugged. In its review of the evidence provided by the NRC and Edison, Fairewinds compared San Onofre’s data on its plugged tubes to the NRC’s data from other plants that have undergone steam generator replacements in order to determine how severe the damage is at San Onofre in comparison to the industry as a whole.

As evidenced in Figure 1, Edison has plugged 3.7 times more tubes in its San Onofre Units 2 and 3 replacement steam generators than the nationwide total of all plugs inserted in all the remaining replacement steam generators in all US nuclear reactors. Moreover, the NRC and Edison have not openly informed the public about the magnitude of tube generator plugging at San Onofre compared to the remainder of U-tube damage at other US reactors.

**Figure 1**

**U.S. Nuclear Reactors Replacement Steam Generators  
Tubes Plugged to Avoid Generator Failure<sup>3</sup>**

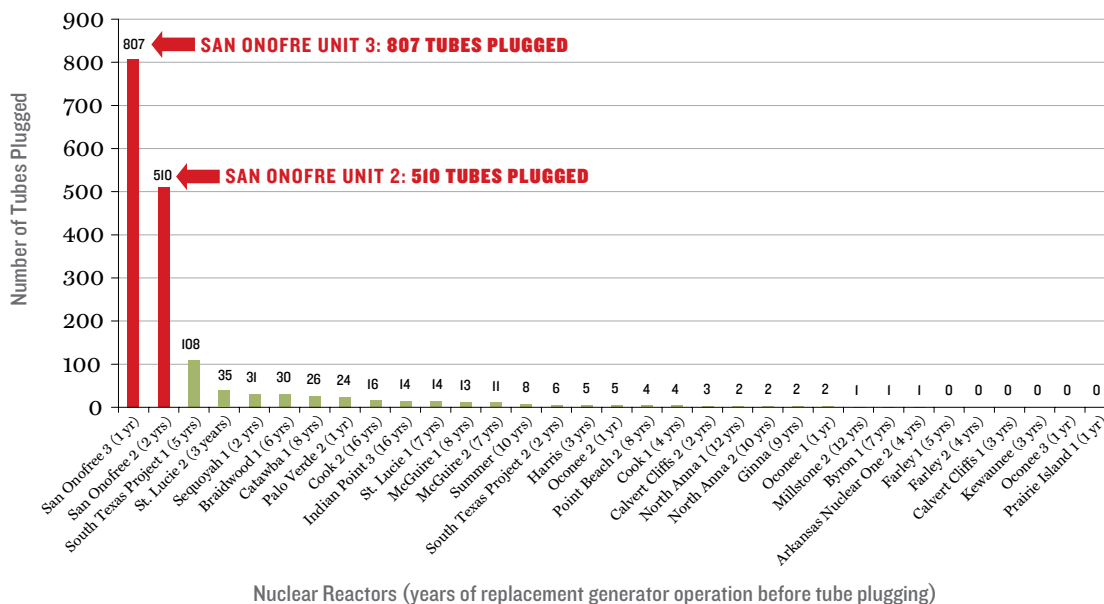

<sup>2</sup> Ibid

<sup>3</sup> U.S. reactors with Alloy 690 steam generator tubes, and years generators in operation. NRC NUREG-1841 U.S. Operating Experience with Thermally Treated Alloy 690 Steam Generator Tubes. Source: <http://pbadupws.nrc.gov/docs/ML0723/ML072330588.pdf>

### **Mechanisms That Created Tube Damage In Unit 2 Are Identical To Those In Unit 3**

Even a casual overview of the data presented in Figure 1 shows an alarming difference at San Onofre in comparison to other operating US nuclear reactors. The minor differences between the replacement steam generators at San Onofre Units 2 and 3 are inconsequential when those steam generators are compared to replacement steam generators at all other US nuclear power plants.

More tubes are plugged in the replacement steam generators at ***EITHER*** San Onofre Unit 2 or Unit 3 than the total number of plugged tubes at every other replacement steam generator in every nuclear plant in the US.

Edison maintains that San Onofre Unit 2 should be allowed to restart because it has a steam generator that is *better than* the one in San Onofre Unit 3. Fairewinds notes, however, that the Unit 2 steam generators would be the worst in the nation except that San Onofre Unit 3 has earned that dubious distinction.

Moreover, the replacement steam generators at San Onofre Unit 2 and Unit 3 were designed to the same specifications, were modeled using the same flawed and inadequate computer codes, and both units have the same high velocity fluid elastic instability (FEI) that is one of the causes of the significant tube degradation.

Each Unit's replacement steam generators have the same failure modes. Both Unit 2 and Unit 3 have experienced tubes colliding with each other (tube to tube damage) as well as tubes colliding with structures inside the steam generator that were designed to prevent tube damage (anti-vibration bars, tube support plates, and retainer bars). Both Units experienced wear due to FEI (fluid elastic instability) and turbulence induced vibration. In addition, Unit 2 exhibited wear due to the collision of a foreign object with the tubes while Unit 3 did not.

On pages 12-14 of its *Condition Report*<sup>4</sup> issued May 7, 2012, Edison acknowledged the similar failure modes between the two units. **“The location of the tube-to-tube wear in the Unit 2 SG was in the same region of the tube bundle as in the Unit 3 SGs. This indicates the existence of causal factors similar to those resulting in tube-to-tube wear in the Unit 3 SGs.”** (Emphasis Added).

Edison elaborated on this condition and said:

“This supplemental rotating probe examination covered the U-bend portion of approximately 1300 tubes in each SG. This inspection identified additional tube wear indications in tube free spans, at AVBs [anti-vibration bars], at TSPs [tube support plates], at retainer bars, and due to a foreign object.”

---

<sup>4</sup> Edison *Condition Report: 201836127*, Revision 0, 5/7/2012, Root Cause Evaluation: Unit 3 Steam Generator Tube Leak and Tube-to-Tube Wear, San Onofre Nuclear Generating Station, Page 14

*The following tables and descriptions on this page are extracted from the attached Edison Condition Report: 201836127, Revision 0, 5/7/2012, Root Cause Evaluation: Unit 3 Steam Generator Tube Leak and Tube-to-Tube Wear, San Onofre Nuclear Generating Station:*

#### Extent of Condition - Tube-to-Tube Wear<sup>5</sup>

Tube Degradation	Unit 2 – Tubes Affected	Unit 3 – Tubes Affected
Tube-to-Tube Wear	2	326

**Extent of Tube-to-Tube Wear (Unit 3)** – The tube leak, eight in-situ tube pressure failures and a total of 326 tubes with tube-to-tube wear was unexpected in the recirculating SGs, and especially new SGs, half-way through their first operating cycle.

**Extent of Tube-to-Tube Wear (Unit 2)** – The location of the tube-to-tube wear in the Unit 2 SG was in the same region of the tube bundle as in the Unit 3 SGs. This indicates the existence of causal factors similar to those resulting in tube-to-tube wear in the Unit 3 SGs.

#### Extent of Condition - Tube-to-Support Wear

Tube Degradation	Unit 2 – Tubes Affected	Unit 3 – Tubes Affected
AVB Wear	1399	1767
TSP Wear	299	463
Retainer Bar Wear	6	4

**Extent of Tube-to-AVB Wear (Units 2 and 3)** – In the Unit 2 SGs, there were 1399 tubes with tube-to-AVB wear and in the Unit 3 SGs, there were 1767 tubes. Of these tubes, four tubes in Unit 2 and one tube in Unit 3 were stabilized and plugged in accordance with the SG Program (see CA Matrix). This evaluation considered two distinct wear patterns, one associated with tubes that also have tube-to-tube wear and the other associated with out-of-plane vibration. For the tubes that show tube to AVB wear that are not associated with the tubes exhibiting FEI, the wear is caused by turbulence induced vibration.

**Extent of Tube-to-TSP Wear (Units 2 and 3)** – In the Unit 2 SGs, there were 299 tubes with tube-to-TSP wear and, in the Unit 3, there were 463 tubes. ... Many of these tubes were stabilized and plugged as a result of both tube-to-tube wear and tube-to-TSP wear. ... For the tubes that show tube to TSP wear that are not associated with the tubes exhibiting FEI, the wear is caused by turbulence induced vibration...[and there exists] similarity in tube numbers between units regarding wear at the TSPs.

#### Extent of Tube-to-Retainer Bar Wear (Unit 3)

Tube-to-retainer bar wear was first identified in the Unit 2 SGs by ECT during the first refueling outage following SG replacement. The wear was unexpected.... The tube wear was adjacent to the small diameter retainer bars. The identified cause was inadequate bar design, and the corrective action was to plug all 94 tubes adjacent to the retainer bars to eliminate any potential for occurrence of a primary to secondary leak. ... a focused ECT inspection was performed in the Unit 3 SGs, which identified three tubes with wear at the retainer bars greater than 35%. The corrective actions for the Unit 3 SGs included plugging these three tubes and preventive plugging of a total of 94 tubes adjacent to small diameter retainer bars in each Unit 3 SG.

#### Extent of Condition - Foreign Object Wear

Tube Degradation	Unit 2 – Tubes Affected	Unit 3 – Tubes Affected
Foreign Object	2	0

<sup>5</sup> Ibid, Page 12

Edison maintains that since only 800 tubes have been plugged in San Onofre Unit 3 and “only” 500 have been plugged at Unit 2, that Unit 2 is in great shape and therefore should be considered for restart. However, while Edison has shown that the number of tubes they plugged at Unit 2 was less than the number plugged at San Onofre Unit 3, it is clear that the number of degraded tubes plugged at Unit 2 is excessive compared to the remainder of the operating US nuclear power plants.

Plugging tubes does not prevent them from vibrating; it only prevents them from releasing radioactive material when they fail from vibration. In addition, the data Fairewinds reviewed shows that more than 4,000 tubes are showing significant wear, while only 1317 have been plugged. Plugging the tubes will not eliminate the fluid-elastic instability or the flow-induced vibration in the more than 4000 tubes that have shown significant wear. This could create cascading tube failures, wherein the kinetic energy from a ruptured tube cuts through neighboring tubes in a domino-like rapid and catastrophic failure that would release significant radiation to the general public.

Look again at Edison’s own *Condition Report*, the “***The location of the tube-to-tube wear in the Unit 2 SG was in the same region of the tube bundle as in the Unit 3 SGs. This indicates the existence of causal factors similar to those resulting in tube-to-tube wear in the Unit 3 SGs.***” This quote from Edison’s *Condition Report* is just one example indicating that the failure modes between Unit 2 and Unit 3 are identical.

### **San Onofre Modifications Created Unanalyzed Accident**

The seriousness of the situation at San Onofre cannot be overstated or underestimated. In order for a nuclear power plant like San Onofre to receive its operating license, the plant owner (in this case Edison) must be sure that any Design Basis Accident (DBA), the worst-case accident scenario envisioned by nuclear engineers, has been accurately modeled so that accurate plans are in place in order to protect public health and safety. Design Basis Accident modeling significantly impacts the design and implementation of Emergency Evacuation Plans.

As Fairewinds has stated in previous reports, if a steam line break accident were to occur it could be more severe than any design basis accident scenario previously analyzed by Edison due to the extensive plugging of San Onofre’s replacement steam generator tubes. Such a DBA steam line break accident would render the San Onofre emergency plan totally inadequate and an evacuation of a large portion of Southern California could be necessary, with no adequate evacuation plan in place.

Fairewinds review of all the evidence presented by Edison and the NRC AIT, shows that the reason San Onofre had to plug 1300 tubes, was that the power plants were operating outside their approved licensing parameters in an unanalyzed, unlicensed condition. As a result, NRC licensing procedures and 10 CFR50.59 require that Edison apply for a license amendment for San Onofre Unit 2 and Unit 3 and the NRC conduct the full public hearing process prior to the restart of either Unit 2 or Unit 3.

**Conclusion**

Because the identical failure modes exist in both San Onofre Unit 2 and 3 and because the damage to both Units is especially excessive, when compared to the remainder of the US nuclear power plants, it is Fairewinds' opinion that both Unit 2 and Unit 3 should remain shut down until extensive modifications or fabrication of replacement generators are completed, and Edison is granted the required 10CFR50.59 amendment to San Onofre Unit 2 and Unit 3 operating licenses.

*-End-*

**Attachments:**

Edison *Condition Report: 201836127*, Revision 0, 5/7/2012, Root Cause Evaluation: Unit 3 Steam Generator Tube Leak and Tube-to-Tube Wear, San Onofre Nuclear Generating Station